

Undermine

Kenny Wong Chi-Chuen

Kinetic Video Installation
2016-2018
1.5m * 0.8m * 0.5m



Video: <https://vimeo.com/196929686>

Web: <http://kennywong.co/2016/undermine/>

Kinetic Video Installation

Undermine - to weaken or cause to collapse by removing underlying support, as by digging away or eroding the foundation.

“Undermine” represents the psychological condition of the artist. A slightly unbalanced machine pointing sideways is waiting to spin in high speed. Its kinetic motion comes from a single propeller from quadcopter parts. The noise of the spinning propeller amplifies the uneasiness, tension and fragility of the human depiction that spins in front of the viewer. The machine rotates at various speeds, randomly decided by the microcomputer. At the same time that is in motion, it attempts to stabilize the LCD display with a video of a woman taken from overhead. To display the girl’s movement in a transparent screen, a normal LED TV is disassemble, modified and backlit by a custom circular light.

Together, the sculptural machine contrasts and balances a disturbing physical movement with the slow pace of a natural body movement. Undermine plays on the balance of attraction and repulsion, on spin and counter-spin, and the sense of dangerousness and fragility. As a work it represents the constant maladaptive psychological status of the individual, in the constant act of balancing.

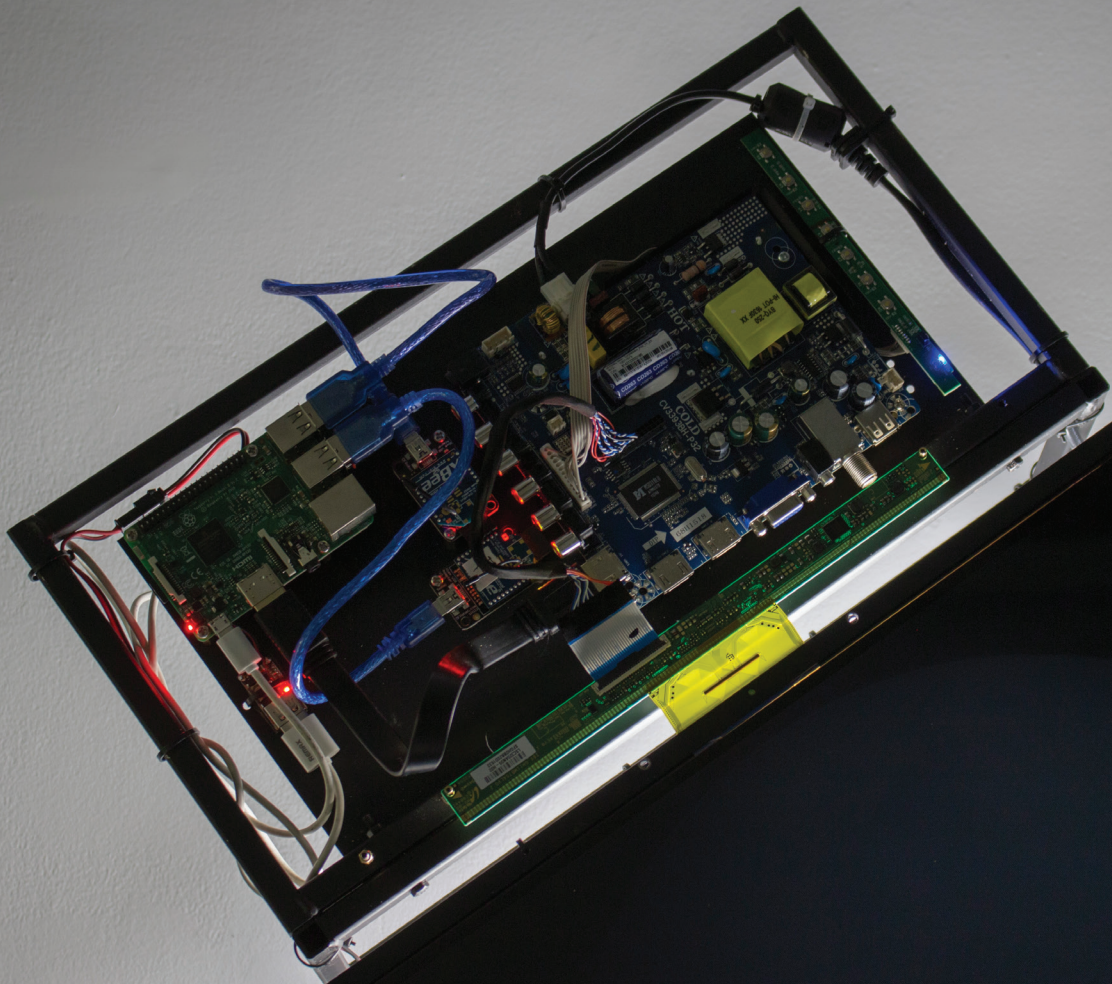

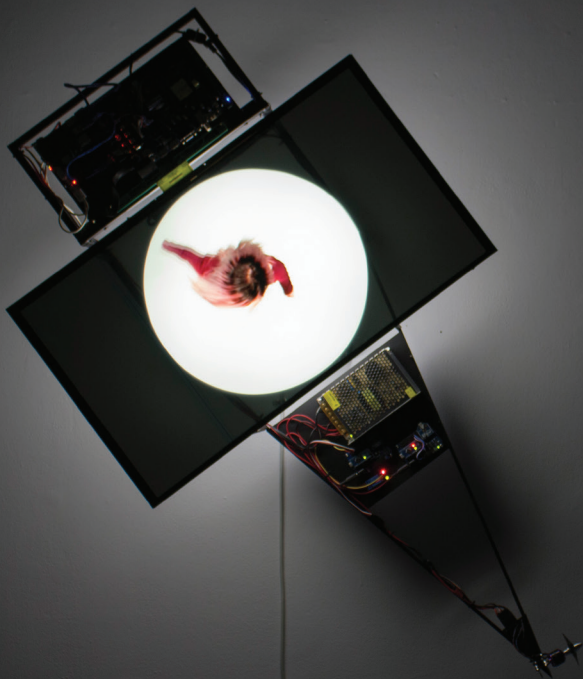
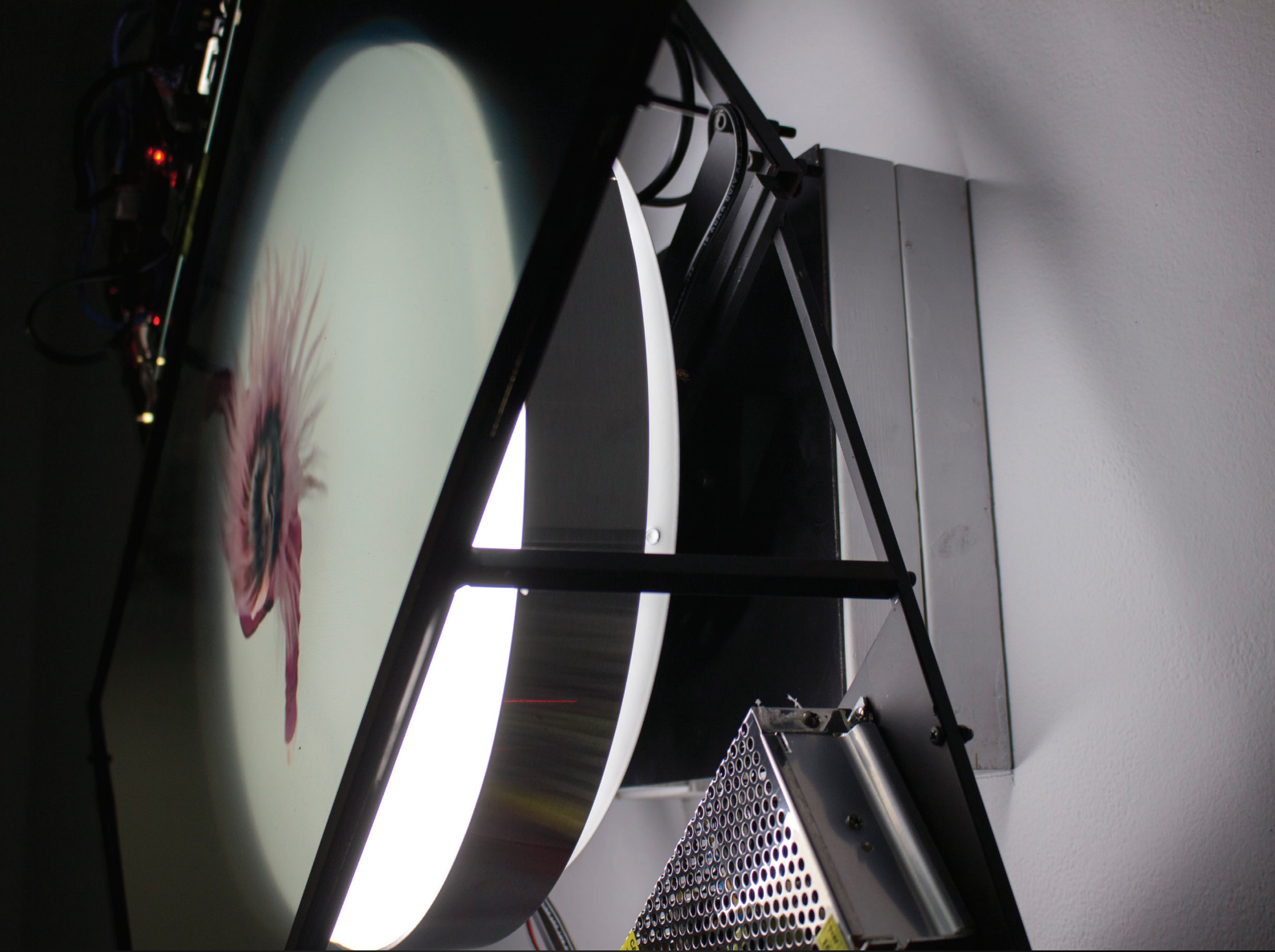

Undermine

Kenny Wong Chi-Chuen

Technical Rider



Space Requirement

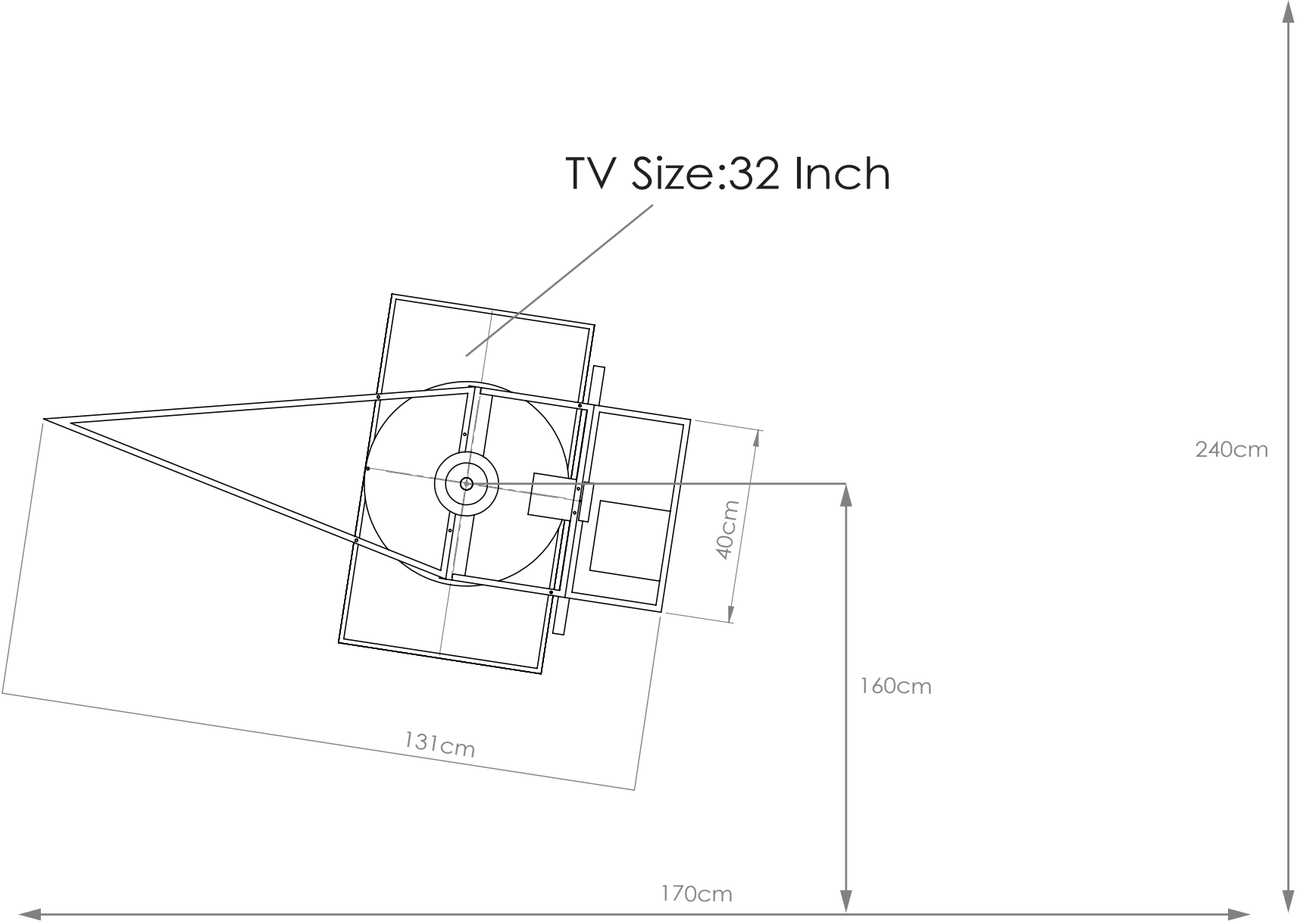

Technical Requirement

Drillable wall that can hold more than 50lbs

Wall Size: 170cm(W) * 245cm(H)

AC Power (220VAC OR 120VAC with 200W Inverter)

Dark Space, Optimum View Either

Narrow Room < 2m or Approach from far
for the sound reflection and lighting

Fragile Display and High Speed Propeller
(warning tape / sign is needed)